

Plastic Solutions Inc.  
 238 McGhee Rd.  
 Winchester, VA. 22603  
 1-877-877-5227  
 www.StormRax.com



FINISH:

**PART LIST**

#	QTY.	PART INFORMATION
1		

1		
---	--	--

**INFORMATION**

	DIM. LOCATION	SIZE
1	H	
2	L	
3	PH	
4	PW	
5	PIPE SIZE	
6	Ø	
7		

**JOB INFORMATION**

CUSTOMER:

PROJECT NAME:

JOB #:

TOLERANCES  
 X: +/- 1/16  
 ANGULAR: +/- .5 DEG

DRAWN BY: RB DATE: --

CHECK BY: DATE: --

REV. -- SHEET 1 OF 1

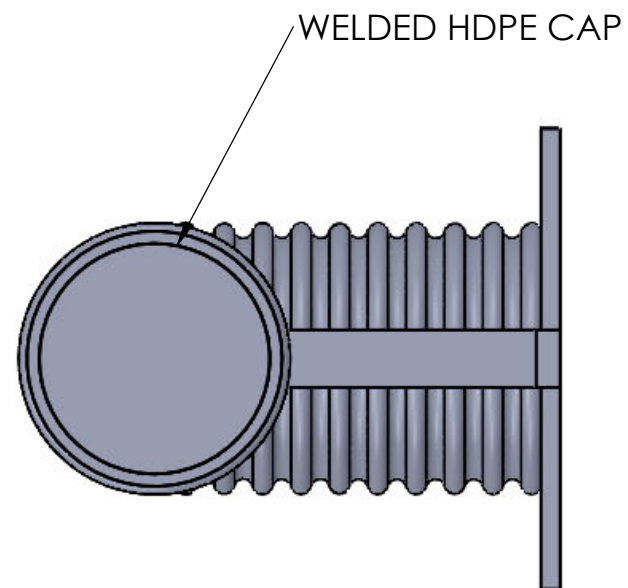

WELDED HDPE CAP

